

KOHLTECH

Solutions For Every Industry & Every Build

MON-7TSM Manual

KOHLTECH
VIDEO MANAGEMENT CENTER



Live



Playback



Evidence

PRODUCT MANUAL



1 Product Characteristic

1.1 Overview

The 7TS is a control panel used for bus intelligent dispatch system. Adopted with 18 buttons, 7 inches large screen display, it also integrates with features of SMS, reversing monitor and driver swipe card etc..It is widely applied to domestic and overseas bus systems for its easy installation, powerful features and convenient operation.

1.2 Features

1.2.1 Control Panel

7TS controls MDVR via RS232 serial port and driver can setup MDVR on 7TS .

The function of 7TS is similar to remote control. Besides, it also can setup the menu of MDVR.

1.2.2 Bus Station Announcer

It works with MDVR (supported only with firmware of bus station announcer version) to announce the stations manually/ automatically.

1.2.3 Live View

Menu and video can be transmitted to 7TS via pass through mode. 7TS can setup the other functions of MDVR, such as record and playback.

1.2.4 Reversing Live View

There is an AV aviation-din on 7TS, drivers can connect the camera with 7TS. It is not used for recording or monitoring, but to view the reversing vehicle and other live view. Besides, there is a sensor using to connect with I/O signal, which is to switch the pictures of camera.

1.2.5 Drivers Swipe Card

There is a built-in RFID module in 7TS, which is used for drivers to sign in and sign out. The information will be uploaded to platform via MDVR network.

1.2.6 SMS and Voice Broadcast

Built-in 2 speakers(16Ω, 2w), they are used to broadcast messages and some prompts

1.2.7 Intercom

Connect with microphone and MDVR, it can realize the functions of speaking inside/outside of the vehicle, IP connection and making calls.

1.3 Product structure

1.3.1 Product appearance and size.



Front Panel of 7TS

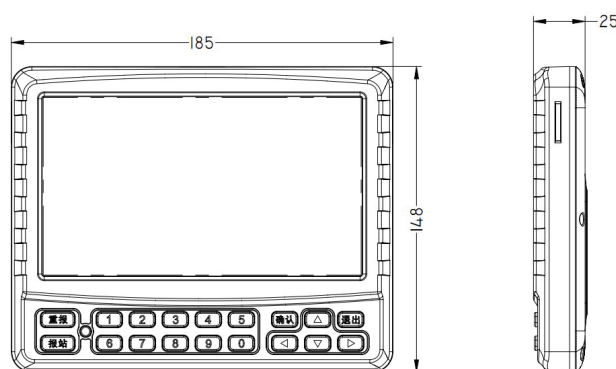

Dimension of 7TS

1.3.2 Button Introduction

The 7TS has with 18 buttons, including 1-0 number buttons, 4 function buttons and 4 arrow buttons for bus control and scheduling application.

- a. When drivers press number 1-5, it broadcasts the messages set before and if there is no message, it would not broadcast anything. (Supported only with firmware of bus station announcer version) Example : When drivers press 1, it broadcasts Please take care of your belongings.
- b. When drivers press number 6-0, it sends message set before, and if there is no message, it does not send anything. Example: When drivers press 9, it will send a message to request schedule. If it is done successfully, the center will send a confirmed message back and the bus station announcer will broadcast it automatically.
- c. When drivers press Broadcast Again, the speaker will broadcast the the message again, or switch the inside calling to outside calling, or interrupt outside calling. Example : When it is live-view or menu interface, the screen will turn to the main interface after drivers press Broadcast Again.
- d. When drivers press Broadcast, the speaker will broadcast the next bus station information inside and outside of the vehicle.

Example : If the speaker says **we are arriving XX**, and it will turn to **we are leaving XX** when pressing Next Stop.

- e. Press Enter to view system information and open the selected menu.
- f. Press Exit to exit current interface and switch from the main interface to the live-view interface.
- g. Press **◀** to go left, exit the current status, switch the module, or interrupt the outside calling.
- h. Press **▲** and **▼** to go up or down.
- i. Press **▶** to go right or stop the current broadcast.

1.3.3 Product Specification

Items	Parameter	Performance Index
Specifications of Screen	Size	7 Inches
	Resolution	800*480
	Aspect Ratio	16:9
	Button and Screen Distribution	Combined
Material	Panel Material	70%PC+30%ABS Engineering plastics
	Button Material	Silicone
Built-in Module	RFID Wipe Card Module	13.56 MHZ for driver to sign in and sign off.
	Speaker	Speaker(16Ω, 2W)x2
Interface	MDVR Interface	Connects to MDVR
	CAM Interface	Yellow 4PIN aviation-din connector, connects to reversing camera
	MIC Interface	Connects to the driver microphone
	SENSOR Interface	Yellow hanging line, reversing signal detection port, high level effective. To monitor control for reversing.
Button	Function Buttons	Restate / station announcer / Arrow Keys / Confirmation / Exit
	Number Buttons	0-9
Installation	Tile Installation	Refer to mounting bracket.
	Bracket Installation	There are three brackets with hood.
Dimension	185mm×128mm×34.9mm	
Operation Parameters	Operating Voltage	12V
Performance Parameters	Operating Current	200mA
	Total Power Consumption	2.4W
	Waterproof and Dustproof	IP53
	Operating Temperature	-20°Ê~+70°Ê
	Relative Humidity	8%~90%

1.3.4 LCD Specification

LCD Parameters	Performance Index	Description
Screen Type	LCD screen	
Touch Type	4 wire resistor type	
Size	7 inches	
Resolution	800*480	
Luminance	400cd/m2	
Contrast Ratio	20.83402778	Under a suitable brightness condition, the higher contrast, the richer color levels
Response Time	10/15(Tr/Td) ms	The response time of the LCD to the input signal
Visual Angle	70/70/50/70 (Typ.)(CR dot 10)(Left/Right/Up/Down)	
Maximum Number of Display Color	262K/16.7M(6bit/6bit+Dithering)	
Scale	16:9	
Back-light Type	White LED	

1.3.5 Bracket Installation

7TS supports bracket installation, and there are three brackets to be chosen:

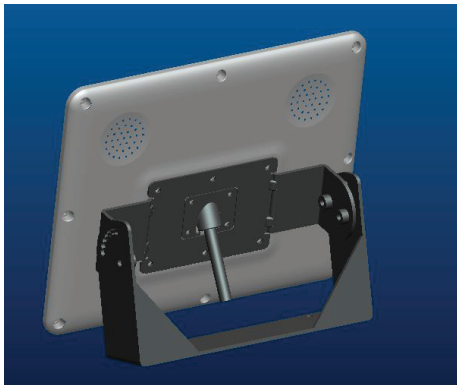

Suitable for relatively flat console

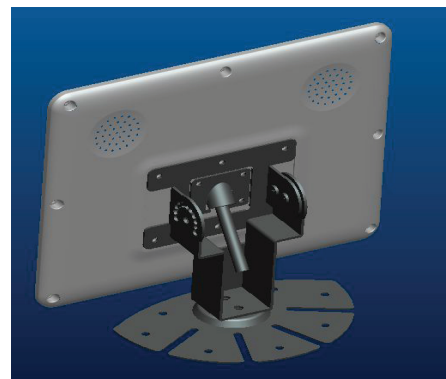

Suitable for curved console

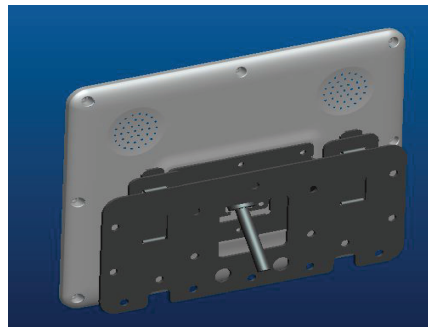

Suitable for hanging

1.3.6 Interface

To ensure the waterproof, the external interface of the 7TS uses harness, which leads a bunch of buses from 7TS, and then the joint distributes according to their functions, details are as following:

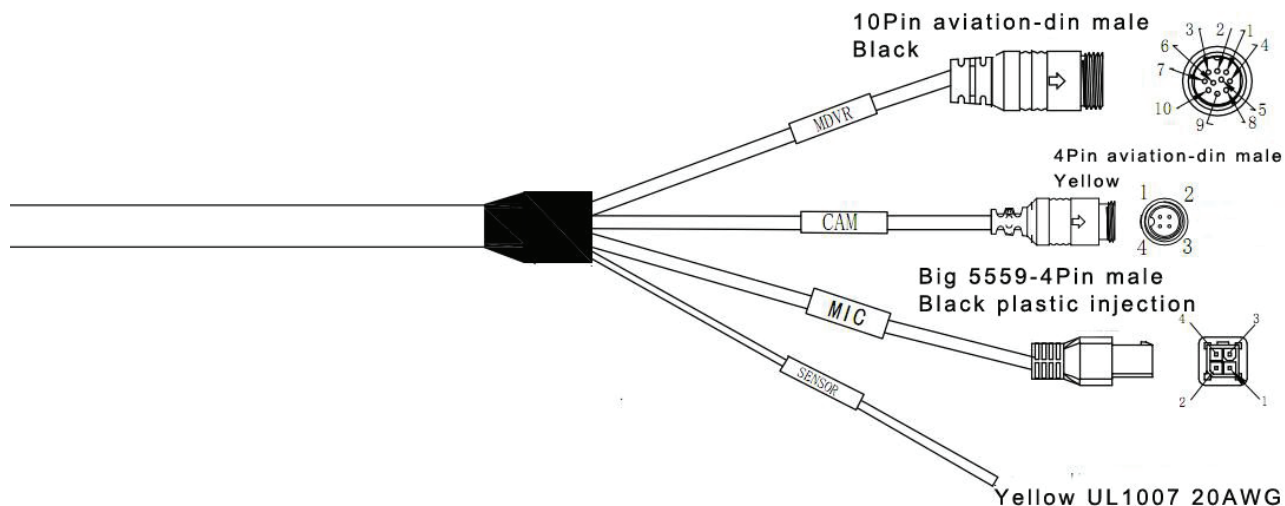

Definition :

Connector Name	Function	Definition
MDVR	Black 10PIN aviation-din male connector connects to the MDVR.	
CAM	Yellow 4PIN aviation-din connector connects to reversing camera.	
MIC	Connects to driver microphone.	
SENSOR	Yellow hanging line, reversing signal detection port, high level effective. For reversing control.	<p>Hanging line</p>

2 Product Performance

2.1 Environmental Performance

Serial No.	Experiment Items	Test Methods
1	Low Temperature Operation	a. Test equipment applies to GB/T 2423.1—2008 b. Put into the cryogenic chamber at $-20^{\circ}\text{C}\pm 2^{\circ}\text{C}$ for 72 hours at 0.85 times rated voltage. During this time, cut off the power for 1 hour and reconnect the power for 1 hour repeatedly until the end of the test.
2	Low Temperature Storage	a. Test equipment applies to GB/T 2423.1—2008 b. Put into the cryogenic chamber at $-40^{\circ}\text{C}\pm 2^{\circ}\text{C}$ for 8 hours without power supply. Recover to normal temperature after the test.
3	High Temperature Operation	a. Test equipment applies to GB/T 2423.2—2008 b. Put into the high temperature chamber at $+70^{\circ}\text{C}\pm 2^{\circ}\text{C}$ for 72 hours at 1.25 times rated voltage. During this time, cut off the power for 1 hour and reconnect the power for 1 hour repeatedly until the end of the test.
4	High Temperature Storage	a. Test equipment applies to GB/T 2423.2—2008 b. Put into the high temperature chamber at $+85^{\circ}\text{C}\pm 2^{\circ}\text{C}$ for 8 hours without power supply. Recover to normal temperature after the test.
5	Temperature Shock	a. Test equipment applies to GB/T 2423.1—2008 and GB/T 2423.2—2008 b. Test cycles with the following procedures without power supply for 24 hours: <ul style="list-style-type: none"> —Keep $-40^{\circ}\text{C}\pm 2^{\circ}\text{C}$ for 2 hours; —Keep $-40^{\circ}\text{C}\pm 2^{\circ}\text{C}$ for 1 hour; —Keep $+85^{\circ}\text{C}\pm 2^{\circ}\text{C}$ for 2 hours; —Keep $+85^{\circ}\text{C}\pm 2^{\circ}\text{C}$ for 1 hour; —Keep $+23^{\circ}\text{C}\pm 5^{\circ}\text{C}$ for 2 hours.
6	Steady Damp-Heat	Test equipment applies to GB/T 2423.3—2006 Keep for 24hours at $+40^{\circ}\text{C}\pm 2^{\circ}\text{C}$, 90%~95% non-condensing without power supply.

2.2 Mechanical Environmental Performance

Serial No.	Experiment Items	Test methods
1	Impact	<ul style="list-style-type: none"> a. Test equipment and method apply to GB/T 2423.5—2008 b. Normal installation and without power supply, the peak acceleration is 490 m/s² and pulse duration is 11 ms. Six sides do these steps 3 times.
2	Vibration	<ul style="list-style-type: none"> a. Test equipment and method apply to GB/T 2423.10—2008 b. Normal installation and without power supply, the vibration frequency is 5 Hz ~ 300 Hz and scanning speed is 1 otc/min. In 5 Hz ~ 11 Hz frequency range, the amplitude is 10 mm. In 11 Hz ~ 300 Hz frequency range, the vibration acceleration is 50 m/s². On X, Y, Z three mutually perpendicular axis, each axial does it for 8 hours.
3	Crash	<ul style="list-style-type: none"> a. Test equipment and method apply to GB/T 2423.6—1995 b. Without power supply and any external protections, Peak acceleration is 150 m/s², rated pulse duration is 6 ms. Per direction collision is 100±5 times
4	Drop	<ul style="list-style-type: none"> a. Test equipment and methods apply to GB/T 2423.8—1995 b. Without power supply and any external protections, it falls from 500 mm height



Solutions For Every Industry & Every Build